

Ax1

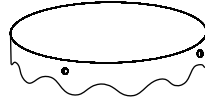

Bx1



Cx1



Dx8

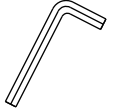

Ex1

1

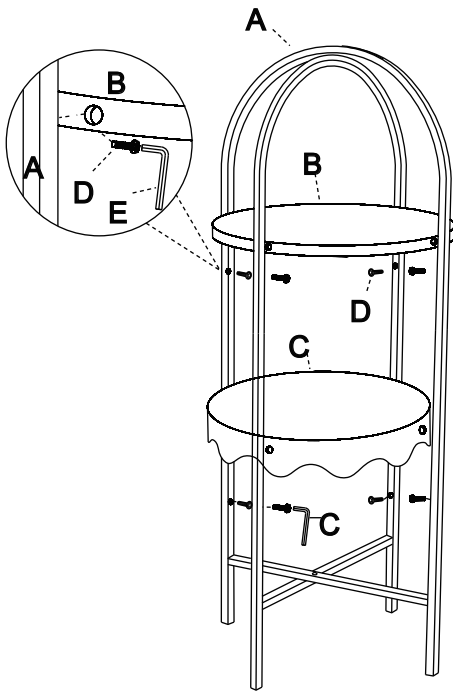

2

